

LIQUID-SPECIFIC PRODUCT LINE: CAST IRON ASPHALT PUMPS

1224A-ASP Series™ & 1324A-ASP Series™

Section	1468
Page	1468.1
Issue	B

TABLE OF CONTENTS

Related Products	1
Operating Range.....	1
Series Description	1
Features & Benefits	2
Jacketing	2
Relief Valve Configurations.....	3
O-Pro® Cartridge Seal.....	3
Revolvable Pump Casings.....	3
Cutaway View & Pump Features.....	4
Model Number Key	5
Standard Materials of Construction	5
Special Materials & Options Selection Guidelines	6
Specifications	7
Optional Casings – K through RS Sizes.....	8
Dimensions – K through Q & M Sizes	9
Dimensions – K through Q & M Sizes (Continued)	10
Dimensions – QS Size	11
Dimensions – N, R & RS Sizes – Jacketed Bracket.....	12
Dimensions – Seal Chamber	13
NPSH Required	14

SERIES DESCRIPTION

The 1224A-ASP Series™ and 1324A-ASP Series™ Asphalt Pumps are designed specifically for handling asphalts, bitumens, pitch, tar, bunker oils, residual oils and related materials that solidify at ambient temperatures.

These asphalt pumps melt ambient-temperature solids to a liquid state prior to pump startup using integral jacketing for steam or hot oil. The ASP pumps are available with Viking's O-Pro® Cartridge seal only. The ASP series is offered in two different models:

ASP1 Models:

The ASP1 model asphalt pumps build upon Viking's proven robust, heavy duty design that has been used for decades of successful asphalt transfer by adding shaft seal leak prevention through use of Viking's O-Pro® Cartridge seal, which utilizes a double O-ring design with grease lubrication to provide a robust seal preventing process fluid from leaking out of the pump. The ASP1 models are best for clean, non-abrasive liquids.

ASP2 Models:

The ASP2 model asphalt pumps are designed for abrasive applications such as the filled asphalts used by manufacturers of asphalt roofing and sealants. These pumps utilize hard parts in key wear areas, combined with unique designs and operating practices to reduce abrasive wear for longest life. These pumps are ideally suited for liquids with concentrations of small but hard particles. The ASP2 model pumps offer shaft seal leak prevention with Viking's O-Pro® Cartridge seal.

RELATED PRODUCTS

Cast Iron, 224A Series™ Pumps: Catalog Section 1402

Cast Iron, 124E Series™ & 324E Series™ Pumps:
Catalog Section 1465

Cast Iron, 34 Series™ Pumps: Catalog Section 1464



K1224A-ASP



N1324A-ASP

OPERATING RANGE

SERIES		NOMINAL FLOW		MAXIMUM PRESSURE		TEMPERATURE RANGE		VISCOSITY RANGE	
		GPM	m³h	PSI	Bar	°F	°C	SSU	cSt
1224A-ASP	ASP1	80 - 400	18 - 91	200	14	0 to +450	-15 to +230	100 to 75,000 *	20 to 17,000
	ASP2	25 - 180	5.6 - 41	150	10	0 to +450	-15 to +230	100 to 2,000,000	20 to 440,000
1324A-ASP	ASP1	550 - 1,500	125 - 340	200	14	0 to +450	-15 to +230	100 to 75,000 *	20 to 17,000 *
	ASP2	210 - 350	50 - 80	125	9	0 to +450	-15 to +230	100 to 2,000,000	20 to 440,000

* Consult factory for viscosities exceeding the stated operating range

Note: O-Pro® Cartridge Seal is patent pending.

Section	1468
Page	1468.2
Issue	B

LIQUID-SPECIFIC PRODUCT LINE: CAST IRON ASPHALT PUMPS

1224A-ASP Series™ & 1324A-ASP Series™

FEATURES & BENEFITS

- Positive Displacement Internal Gear pumping principle handles a broad range of viscosities with constant flow rate
- Axial rotor thrust is controlled by double row ball bearing or tapered roller bearings; a bushing provides a secondary point of radial shaft support
- Rotatable bearing housing provides easy rotor end clearance adjustment to compensate for viscosity or wear
- Gear and pump geometry has been optimized based on more than 100 years of experience
- Footed cast iron bracket provides rigid mounting to help maintain alignment, which extends seal and bearing life
- Can use direct drive, gear reducer or gearmotor drive, or belt-drive
- Series designed with an enlarged bearing housing. Used in conjunction with a spacer coupling permits easy cartridge seal or O-Pro® seal installation and removal in place without removing the head and rotor/shaft.
- Shaft sealing utilizes O-Pro® Cartridge seal. This double O-ring seal design provides superior leak mitigation on asphalt service compared to traditional packing and mechanical seal alternatives.

JACKETING

Jacketed pumps provide a cavity, or jacket, on the external wall of the pump through which steam or heat transfer liquid can be passed to control the temperature of the fluid in the pump. The heat transfer medium flows in a closed loop back to the boiler or heater. Applications include “melting” ambient temperature solids like asphalt which solidify in the pump when it cools. Jacketed ports are threaded.

Standard-Jacketed Pumps

All 1224A-ASP Series™ and 1324A-ASP Series™ pumps include jacketing. Standard construction features jacketing on the head and bracket only and are typically used for melting ambient temperature solids. Relief valve options are available for ASP1 models. See relief valve configuration section for details.

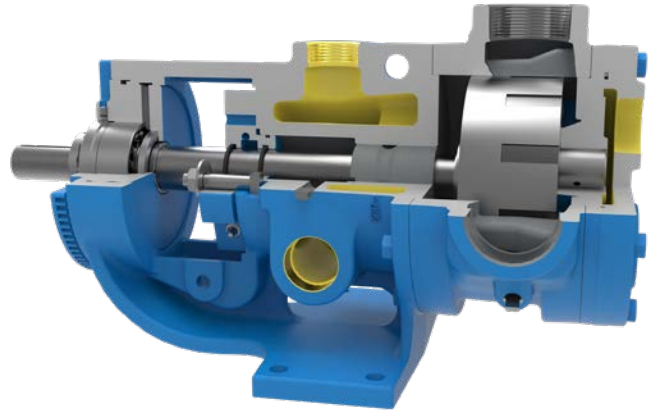

Standard-Jacketed Pump Cutaway – K1224A-ASP

3 Year Limited
Warranty

For warranty details, please go to:
vikingpump.com/warranty

LIQUID-SPECIFIC PRODUCT LINE: CAST IRON ASPHALT PUMPS

1224A-ASP Series™ & 1324A-ASP Series™

Section	1468
Page	1468.3
Issue	B

RELIEF VALVE CONFIGURATIONS

1224A-ASP Series™ and 1324A-ASP Series™ pumps are provided with a jacketed head with no relief valve as standard. Integral pressure relief valves are available for ASP1 models. Integral pressure relief valves are not recommended for products containing solids that may settle out in the valve. K-KK size relief valves are non-jacketed, and L-N size relief valves are jacketed. All K-N size pumps with a relief valve require a non-jacketed valve-type head.

The R size pumps are available with a jacketed bracket, a jacketed head and a non-jacketed relief valve. RS models have a jacketed bracket and head with no relief valve.

See table below for jacketing configurations with and without an integral pressure relief valve (RV).

Pump Size	Bracket	Head	RV
K, KK w/o RV	Jacketed	Jacketed	N/A
K, KK w/ RV	Jacketed	Non-Jacketed	Non-Jacketed
L, LQ, LL, LS, Q, QS, M, N w/o RV	Jacketed	Jacketed	N/A
L, LQ, LL, LS, Q, QS, M, N w/ RV	Jacketed	Non-Jacketed	Jacketed
R, RS w/o RV	Jacketed	Jacketed	N/A
R w/ RV ①	Jacketed	Jacketed	Non-Jacketed

① Relief valve not available for RS size.

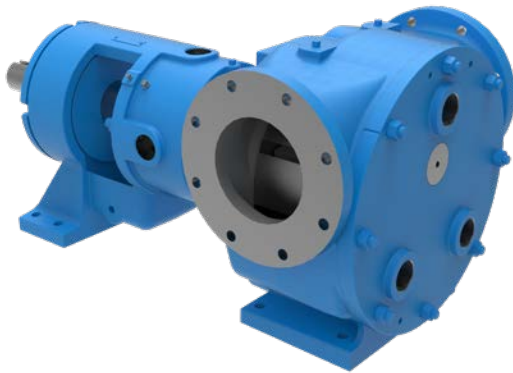

N1324A-ASP with Jacketed Head

O-PRO® CARTRIDGE SEAL

Instead of using traditional packing sealing methods, which must leak, the ASP Series pumps use Viking's O-Pro® Cartridge seal, which uses O-rings and gaskets to seal externally on the bracket and internally on the shaft. These O-rings in combination with a lubricating grease provide a robust seal, keeping process fluid from leaking out of the pump. The O-Pro® Cartridge seal can be easily repaired or retrofitted without pump disassembly. FFKM O-ring materials are standard to allow the seal to withstand the high temperatures common to asphalt applications.

The ASP Series is only available with an O-Pro® Cartridge seal, but the seal chamber design will accept packing, component seals, or cartridge seals.

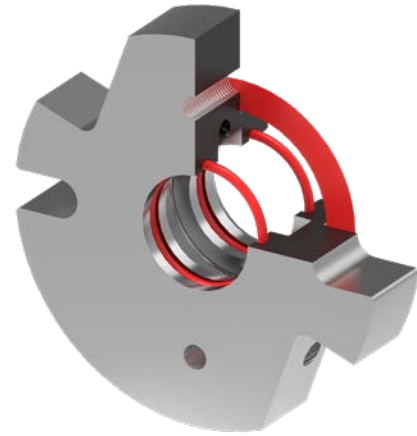

O-Pro® Cartridge Seal Cutaway

REVOLVABLE PUMP CASINGS

90° port options:

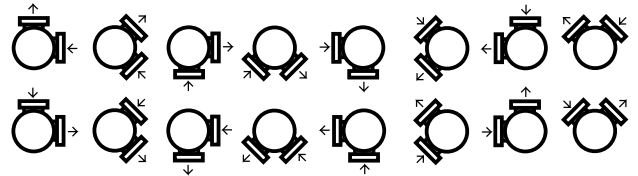

Opposite port options:

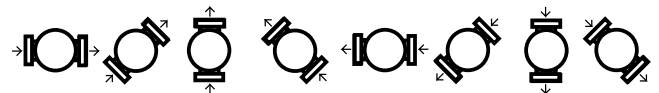

NOTE: See page 1468.8 for a complete list of casing options by size.

Section	1468
Page	1468.4
Issue	B

LIQUID-SPECIFIC PRODUCT LINE: CAST IRON ASPHALT PUMPS

1224A-ASP Series™ & 1324A-ASP Series™

CUTAWAY VIEW & PUMP FEATURES

O-Pro® Cartridge Seal

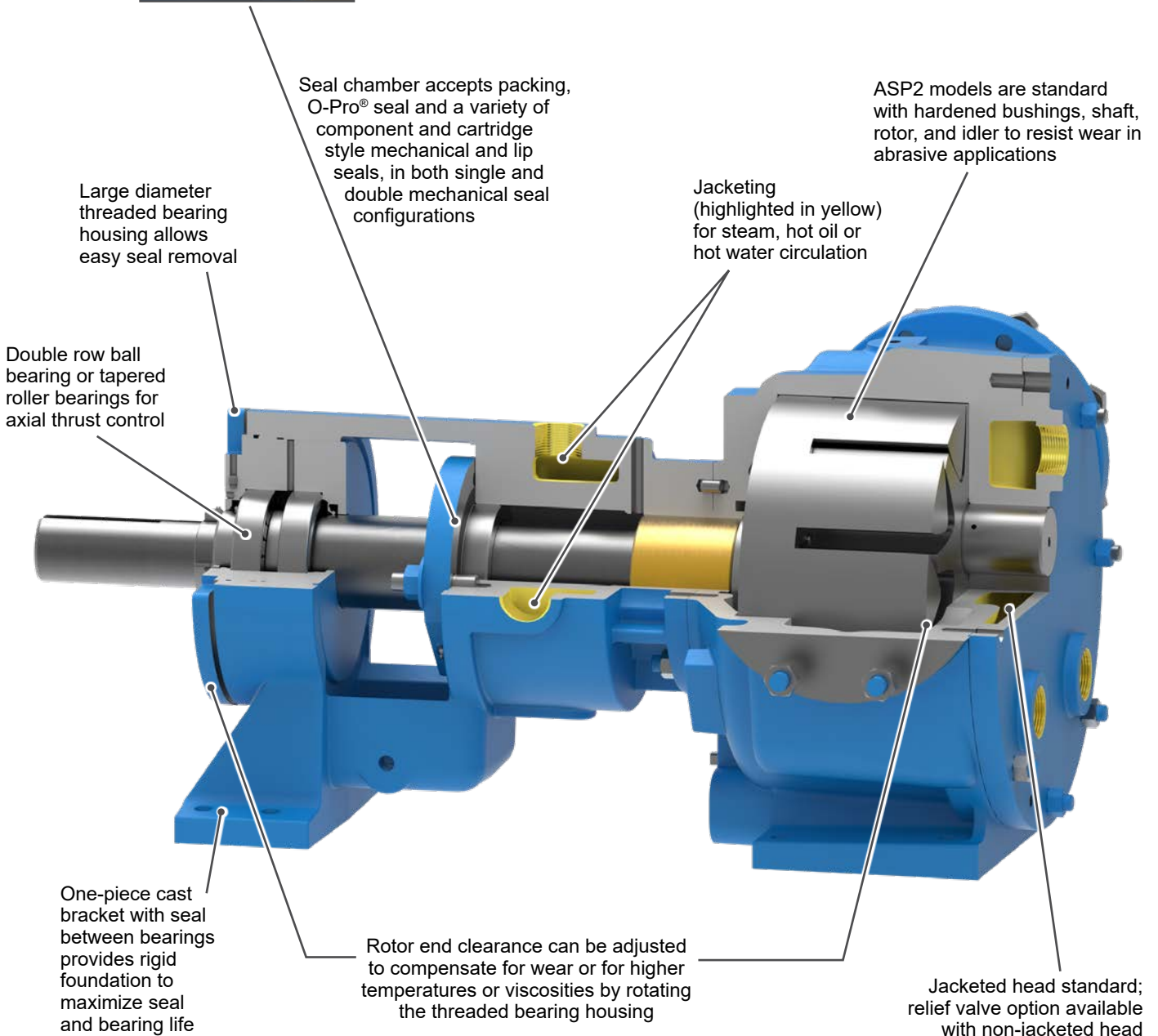
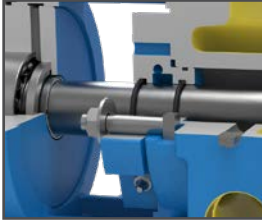

LIQUID-SPECIFIC PRODUCT LINE: CAST IRON ASPHALT PUMPS

1224A-ASP Series™ & 1324A-ASP Series™

Section	1468
Page	1468.5
Issue	B

MODEL NUMBER KEY

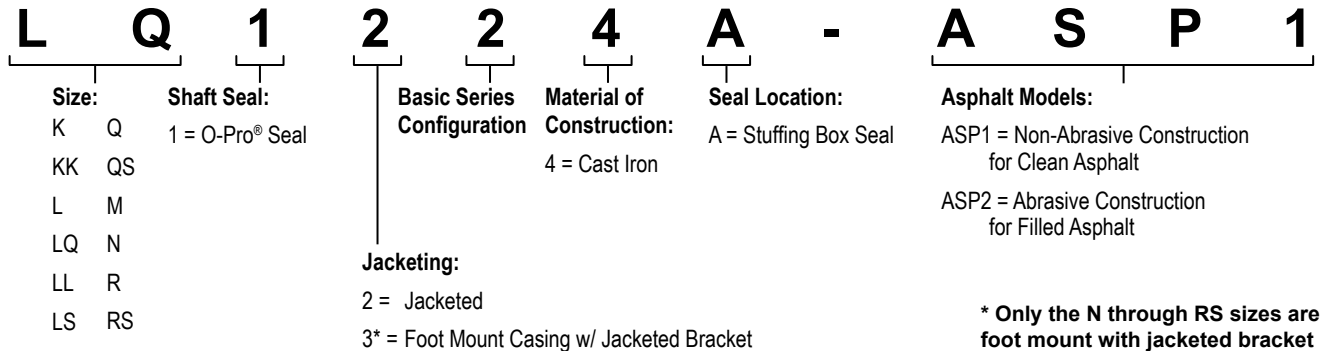

STANDARD MATERIALS OF CONSTRUCTION

Component	Standard Material	
Casing	Cast Iron, ASTM A48, Class 35B	
Head	Cast Iron, ASTM A48, Class 35B	
Head Plate	Cast Iron, ASTM A48, Class 35B	
Bracket	Cast Iron, ASTM A48, Class 35B	
Idler	ASP1	Cast Iron, ASTM A48, Class 35B
	ASP2	Hardened Steel, ASTM A148, Grade 80-40
Rotor	ASP1	② Cast Iron, ASTM A48, Class 35B
	ASP2	③ Hardened Steel, ASTM A148, Grade 80-40
Rotor Shaft	ASP1	④ Steel, ASTM A108, Grade 1045
	ASP2	① Hardened High Strength Steel, ASTM A434, Grade 4140, Class BC
Idler Pin	ASP1	Hardened Steel, ASTM A108, Grade 1045
	ASP2	Tungsten Carbide
Idler Bushing	ASP1	Bronze
	ASP2	Tungsten Carbide
Bracket Bushing	ASP1	Bronze
	ASP2	Hardened Cast Iron
Pressure Relief Valve	⑤ Cast Iron, ASTM A48, Class 35B	
O-Pro® Cartridge Seal	Stainless Steel, FFKM Elastomers	

- ① N and R sizes have Colmonoy #635 coated steel shaft: ASTM A322 Grade 8620.
- ② KK, LS, QS, N and RS sizes have ductile iron rotor: ASTM A536 Grade 60-40-18.
- ③ LS and N hardened steel rotor is ASTM A148 80-50.
- ④ K, KK, L, LQ, LL and LS sizes are high strength steel ASTM A434 Type 4140 Grade BC or equivalent.
- ⑤ RS relief valve not available. Contact factory for options.

Section	1468
Page	1468.6
Issue	B

**LIQUID-SPECIFIC PRODUCT LINE:
CAST IRON ASPHALT PUMPS**
1224A-ASP Series™ & 1324A-ASP Series™

SPECIAL MATERIALS & OPTIONS SELECTION GUIDELINES

For High Viscosities - Above 2,500 SSU (550 cSt)

- Steel fitted construction recommended above the following viscosities, according to pump size:

Viscosity	Pump Size											
	K	KK	L	LQ	LL	LS	Q	QS	M	N	R	RS
SSU	25,000	75,000	25,000	25,000	2,500	75,000	7,500	75,000	25,000	75,000	25,000	75,000
cSt	5,500	17,000	5,500	5,500	550	17,000	1,700	17,000	5,500	17,000	5,500	17,000

- Extra clearances, depending on viscosity. Contact factory for clearance specifications.
- Pump should be operated at slower than normal speeds, which may require a larger pump.
- For viscosities over 250,000 SSU (55,000 cSt), contact factory for additional pump construction and operation recommendations.

For high temperatures – Above 450° F (230°C)

- High temperature bushings recommended depending on temperature, size and specific material. See ESB-3 for recommendations.
- Additional operating clearances may be required depending on temperature, size and specific material. See ES-2 for recommendations.
- For temperatures above 450°F (230°C), special materials and sealing requirements may be needed. Contact factory for recommendations.
- Pump should be operated at slower than normal speeds, which may require a larger pump.

For abrasive or dirty liquids

- If possible, filter or strain out the abrasives present.
- Wear resistant bushings - hardened cast iron or tungsten carbide.
- Abrasive-resistant idler pin - tungsten carbide.
- Hardened or hard-coated shafting.
- For high concentrations of abrasives or particle sizes greater than 250 microns (0.010 in), contact factory for recommendations.
- Pump should be operated at slower than normal speeds, which may require a larger pump.
- Consult factory for specific recommendations.

LIQUID-SPECIFIC PRODUCT LINE: CAST IRON ASPHALT PUMPS

1224A-ASP Series™ & 1324A-ASP Series™

Section	1468
Page	1468.7
Issue	B

SPECIFICATIONS

Model Number	③ Standard Port Size	Nominal Pump Rating (100 SSU & below)			Max. Hydrostatic Pressure ④		① Maximum Discharge Pressure		Max. Recommended Temp. for Standard Pump		Approx. Shipping Weight	
	Inches	GPM	m³/h	RPM	PSIG	BAR	PSIG	BAR	°F	°C	Lbs.	Kg.
K1224A-ASP1	2	80	18	780	400	28	200	14	450	230	117	53
K1224A-ASP2	2	25	6	280	400	28	150	10	450	230	117	53
KK1224A-ASP1	2	100	23	780	400	28	200	14	450	230	117	53
KK1224A-ASP2	2	35	8	280	400	28	150	10	450	230	117	53
L1224A-ASP1	2	135	31	640	400	28	200	14	450	230	161	73
L1224A-ASP2	2	50	11	230	400	28	150	10	450	230	161	73
LQ1224A-ASP1	2 ½	135	31	640	300	21	200	14	450	230	194	88
LQ1224A-ASP2	2 ½	50	11	230	300	21	150	10	450	230	194	88
LL1224A-ASP1	3	140	32	520	300	21	200	14	450	230	205	93
LL1224A-ASP2	3	65	15	230	300	21	150	10	450	230	205	93
LS1224A-ASP1	3	200	45	640	300	21	200	14	450	230	234	106
LS1224A-ASP2	3	72	16	230	300	21	150	10	450	230	234	106
Q1224A-ASP1	4	275	62	470	250	17	200	14	450	230	480	218
Q1224A-ASP2	4	110	25	190	250	17	125	9	450	230	480	218
QS1224A-ASP1	6	400	91	470	250	17	200	14	450	230	580	263
QS1224A-ASP2	6	180	41	190	250	17	125	9	450	230	580	263
M1224A-ASP1	4	420	95	420	250	17	200	14	450	230	600	272
M1224A-ASP2	4	155	35	155	250	17	125	9	450	230	600	272
N1324A-ASP1	6	550	125	330	250	17	200	14	450	230	937	425
N1324A-ASP2	6	210	48	130	250	17	125	9	450	230	937	425
R1324A-ASP1	8	1,000	227	260	250	17	200	14	450	230	1,523	691
R1324A-ASP2	8	350	80	100	250	17	125	9	450	230	1,523	691
RS1324A-ASP1	10	1,500	340	260	250	17	125	9	450	230	1,987	901

① For maximum recommended discharge pressures at different viscosities, see performance curves, which can be electronically generated with the Viking Pump Curve Generator, located on www.vikingpump.com. If suction pressure exceeds 50 PSIG, consult factory. Higher pressures possible with factory approval based on application details.

② Extra clearances are required above 450°F / 230°C. Higher temperatures can be handled with special construction, consult factory.

③ Ports are tapped for standard (NPT) pipe on sizes K through L. Sizes LQ through RS have flange ports suitable for use with Class 125 ANSI cast iron companion flanges or flanged fittings. K through Q & M ports are at 90°

QS, N, R and RS ports are at 180° (opposite)

④ Maximum hydrostatic pressure for standard pump construction. Rating is dependent on seal, gaskets and ports.

Section	1468
Page	1468.8
Issue	B

**LIQUID-SPECIFIC PRODUCT LINE:
CAST IRON ASPHALT PUMPS**
1224A-ASP Series™ & 1324A-ASP Series™

OPTIONAL CASINGS – K THROUGH RS SIZES

Size	Standard Non-Jacketed Casings		Optional Non-Jacketed Casings	Fully-Jacketed Casings
	Ports (Inches)	Rotatable Data		
K	2"①®	Fully Rotatable		
KK	2"①®	Fully Rotatable		
L	2"①®	Fully Rotatable		
LQ	2.5"②®	Ports cannot face down		
LL	3"②®	Fully Rotatable		
LS	3"②®	Fully Rotatable		
Q	4"②®	Fully Rotatable		
QS	6"②◎	Rotatable with special casing	6"②®	
M	4"②®	Fully Rotatable		
N	6"②◎	Not Rotatable		5"②Ⓝ, 6"②Ⓝ
R	8"②◎	Not Rotatable		
RS	10"②◎	Not Rotatable		

- ① Port(s) tapped for standard (NPT) pipe.
- ② Port(s) suitable for use with Class 125 ANSI cast iron companion flanges or flanged fittings.
- Ⓝ Non-Rotatable Ports at 90 degree angle, contact factory for available orientation (right hand or left hand)
- ◎ Opposite Ports
- ® 90° port arranged for Right Hand inlet (viewed from shaft end)

LIQUID-SPECIFIC PRODUCT LINE: CAST IRON ASPHALT PUMPS

1224A-ASP Series™ & 1324A-ASP Series™

Section	1468
Page	1468.9
Issue	B

DIMENSIONS – K THROUGH Q & M SIZES

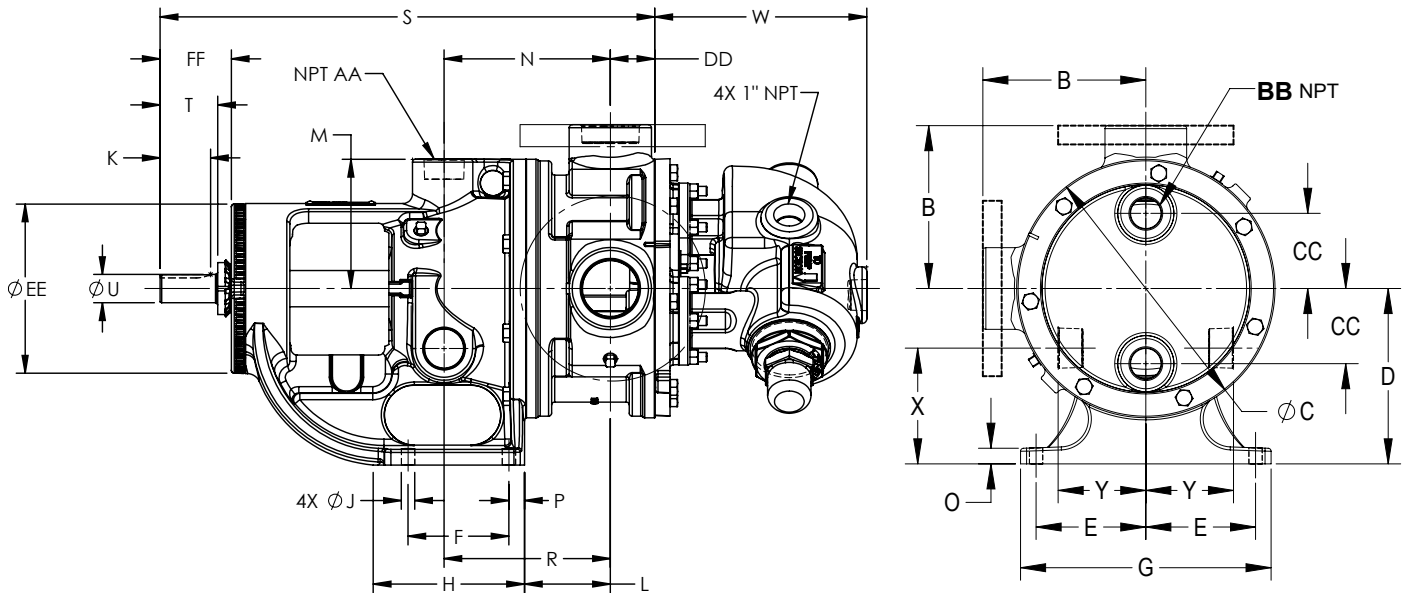

These dimensions are average and not for construction purposes. Certified prints on request.

NOTE: Dimensions "P" through "FF" on next page

Model Number	A		B	C	D	E	F	G	H	J	K	L	M	N	O
O-Pro® Seal	(in)														
K1224A-ASP1 K1224A-ASP2 KK1224A-ASP1 KK1224A-ASP2	① 2	in	5.12	8.00	5.50	4.00	2.75	9.25	4.00	0.53	1.42	3.00	4.00	5.75	0.62
		mm	130	203	140	102	70	235	102	14	36	76	102	146	16
L1224A-ASP1 L1224A-ASP2	① 2	in	6.50	10.25	7.00	4.38	4.00	10.00	5.38	0.53	2.00	3.38	5.12	6.56	0.62
		mm	165	260	178	111	102	254	137	14	50.8	86	130	167	16
LQ1224A-ASP1 LQ1224A-ASP2	② 2.5	in	7.19	10.25	7.00	4.38	4.00	10.00	5.38	0.53	2.00	3.38	5.12	6.56	0.62
		mm	183	260	178	111	102	254	137	14	50.8	86	130	167	16
LL1224A-ASP1 LL1224A-ASP2	② 3	in	7.19	10.25	7.00	4.38	4.00	10.00	5.38	0.53	2.00	3.38	5.12	6.56	0.62
		mm	183	260	178	111	102	254	137	14	50.8	86	130	167	16
LS1224A-ASP1 LS1224A-ASP2	② 3	in	7.19	10.25	7.00	4.38	4.00	10.00	5.38	0.53	2.55	4.75	5.12	7.40	0.62
		mm	183	260	178	111	102	254	137	14	65	121	130	188	16
Q1224A-ASP1 Q1224A-ASP2	② 4	in	8.25	14.00	8.75	4.12	4.00	10.00	6.00	0.69	3.58	6.62	7.00	7.62	0.75
		mm	210	356	222	105	102	254	152	18	91	168	178	194	19
M1224A-ASP1 M1224A-ASP2	② 4	in	9.50	17.35	10.00	5.00	6.00	12.00	8.64	0.69	3.50	7.65	8.63	8.32	1.00
		mm	241	441	254	127	152	305	220	18	89	194	219	211	25

① Ports are tapped for standard (NPT) pipe.

② Ports are suitable for use with Class 125 ANSI cast iron.

Section	1468
Page	1468.10
Issue	B

**LIQUID-SPECIFIC PRODUCT LINE:
CAST IRON ASPHALT PUMPS**
1224A-ASP Series™ & 1324A-ASP Series™

DIMENSIONS – K THROUGH Q & M SIZES (CONTINUED)

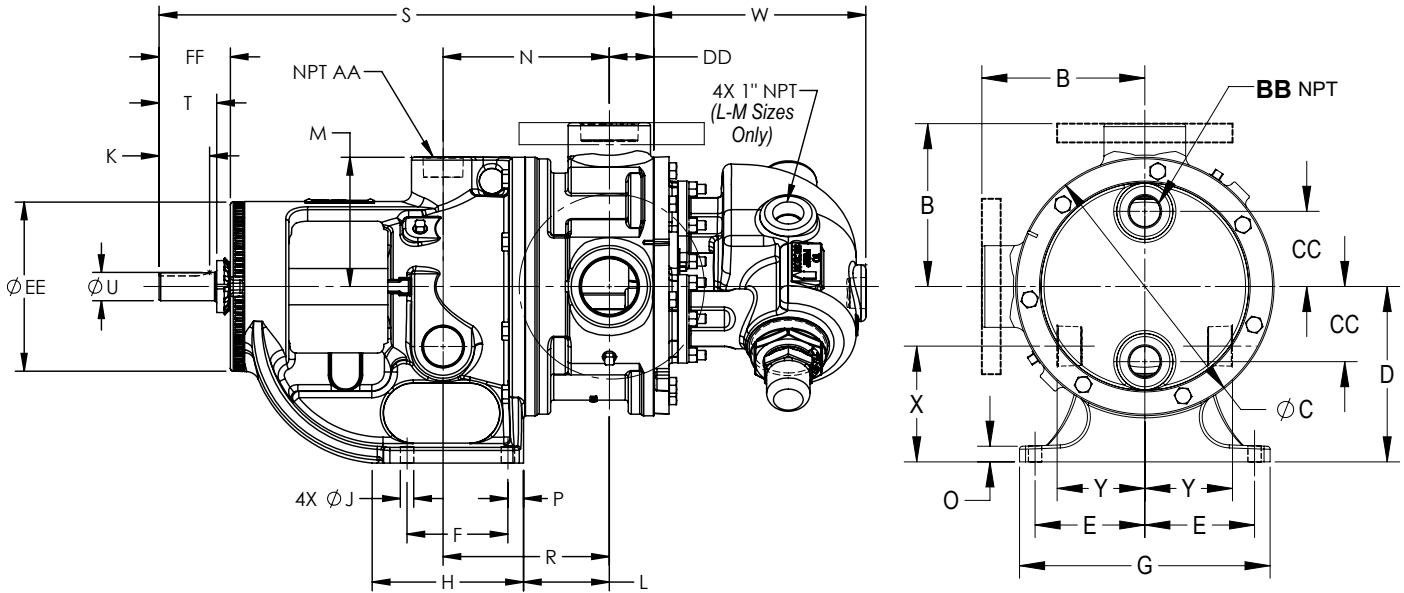

These dimensions are average and not for construction purposes. Certified prints on request.

NOTE: Dimensions "A" through "O" on previous page

Model Number		P	R	S	T	U	V	W*	X	Y	AA	BB	CC	DD	EE	FF
O-Pro® Seal						(in)	(in)				(in)	(in)				
K1224A-ASP1	in	0.62	5.75	16.38	2.25	1.12	.25 x .12	① 7.00	3.38	2.75	1.25	1.25	1.75	3.25	6.75	2.92
K1224A-ASP2	mm	16	146	416	57											
L1224A-ASP1	in	0.62	6.56	17.88	2.25	1.12	.25 x .12	② 10.16	4.62	3.25	1.25	1.00	3.00	3.81	6.75	2.93
L1224A-ASP2	mm	16	167	454	57											
LQ1224A-ASP1	in	0.62	6.56	17.88	2.25	1.12	.25 x .12	② 10.16	4.62	3.25	1.25	1.00	3.00	3.81	6.75	2.93
LQ1224A-ASP2	mm	16	167	454	57											
LL1224A-ASP1	in	0.62	6.56	17.88	2.25	1.12	.25 x .12	② 10.16	4.62	3.25	1.25	1.00	3.00	4.31	6.75	2.93
LL1224A-ASP2	mm	16	167	454	57											
LS1224A-ASP1	in	0.62	7.00	19.25	3.50	1.44	.38 x .19	② 10.73	4.40	3.30	1.25	1.00	3.00	4.50	7.00	4.03
LS1224A-ASP2	mm	16	178	489	89											
Q1224A-ASP1	in	1.00	6.62	23.75	4.50	1.94	.50 x .25	② 13.75	5.50	4.50	1.50	1.25	---	4.57	8.38	5.35
Q1224A-ASP2	mm	25	168	603	114											
M1224A-ASP1	in	1.62	6.96	24.38	4.25	1.94	.50 x .25	② 14.39	5.50	6.00	1.50	1.50	4.33	5.88	8.38	4.96
M1224A-ASP2	mm	41	177	619	108											

* ASP2 models not offered with relief valve. Only available with jacketed head and no relief valve.

① K-KK size relief valve is non-jacketed and used with non-jacketed head.

② L-M size relief valve is jacketed and used with non-jacketed head.

LIQUID-SPECIFIC PRODUCT LINE: CAST IRON ASPHALT PUMPS

1224A-ASP Series™ & 1324A-ASP Series™

Section	1468
Page	1468.11
Issue	B

DIMENSIONS – QS SIZE

Dimensions shown in inches with millimeter equivalent shown in parentheses

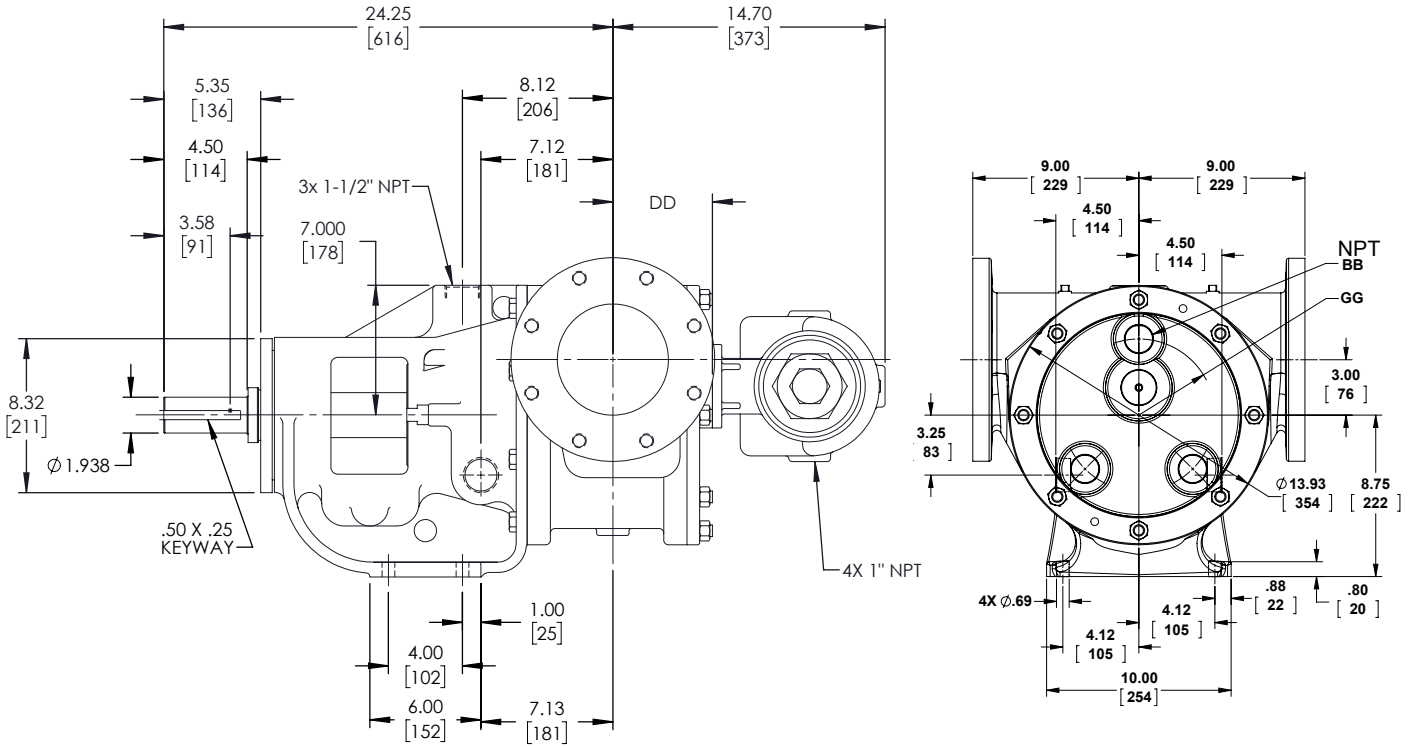

Model Number	BB*	DD	GG
O-Pro® Seal			
QS1224A	1.25	5.57 (141)	4.12 (105)

* Ports for steam or hot oil jacketing are inch standard NPT threads.

1224A-ASP ports suitable for use with Class 125 ANSI cast iron companion flanges or flanged fittings.

NOTE: Flanges are 6", suitable for use with Class 125 ANSI cast iron companion flanges or flanged fittings. They are studded, not through-bolt.

Section	1468
Page	1468.12
Issue	B

**LIQUID-SPECIFIC PRODUCT LINE:
CAST IRON ASPHALT PUMPS**
1224A-ASP Series™ & 1324A-ASP Series™

DIMENSIONS – N, R & RS SIZES – JACKETED BRACKET

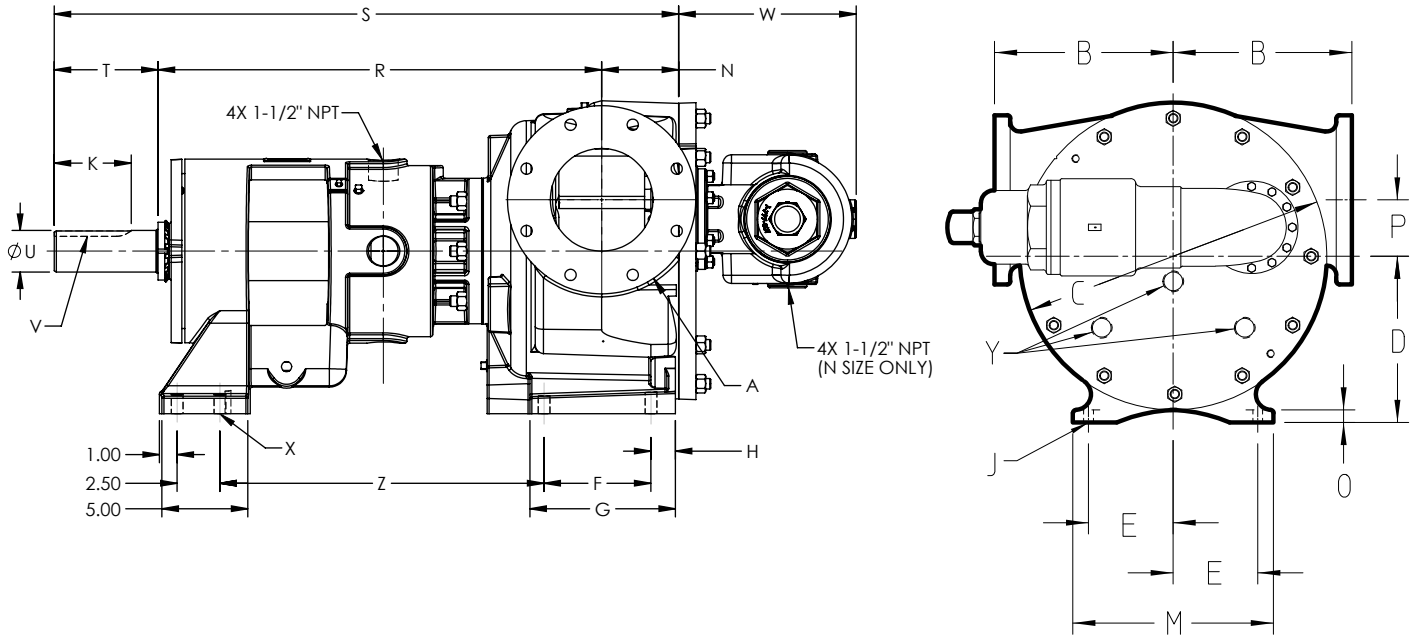

Model Number	A (in)		B	C	D	E	F	G	H	J	K	M
O-Pro® Seal												
N1324A-ASP	① 6	in	9.75	17.25	9.50	5.00	6.25	8.69	1.62	0.69	4.50	12.00
		mm	248	438	241	127	159	221	41	18	114	305
R1324A-ASP	① 8	in	14.25	24.50	13.25	6.75	7.00	10.56	2.31	0.78	6.00	16.00
		mm	362	622	337	171	178	268	59	20	152	406
RS1324A-ASP	① 10	in	14.25	24.50	13.25	6.75	7.00	13.12	4.81	0.88	6.00	16.46
		mm	362	622	337	171	178	333	122	22	152	418

Model Number		N	O	P	R	S	T	U (in)	V (in)	W	X	Y (in)	Z
O-Pro® Seal													
N1324A-ASP	in	4.50	1.00	3.00	26.00	36.50	6.00	2.44	.62 x.31	② 10.34	0.69	N/A	18.94
	mm	114	25	76	660	927	152			② 263	18		481
R1324A-ASP	in	5.62	1.00	4.50	28.75	41.00	6.62	3.44	.88 x.44	③ 12.00	0.69	1.25 NPT	19.25
	mm	143	25	114	730	1041	168			③ 305	18		489
RS1324A-ASP	in	8.12	1.30	4.50	28.55	43.49	6.62	3.44	.88 x.44	④ —	0.88	1.25 NPT	19.25
	mm	206	33	114	725	1105	168			④ —	22		489

- ① Ports are suitable for use with Class 125 ANSI cast iron companion flanges or flanged fittings.
- ② N size relief valve is jacketed and used with non-jacketed head.
- ③ R size relief valve is non-jacketed and used with jacketed head.
- ④ Relief valve not available for RS size.

LIQUID-SPECIFIC PRODUCT LINE: CAST IRON ASPHALT PUMPS

1224A-ASP Series™ & 1324A-ASP Series™

Section	1468
Page	1468.13
Issue	B

DIMENSIONS – SEAL CHAMBER

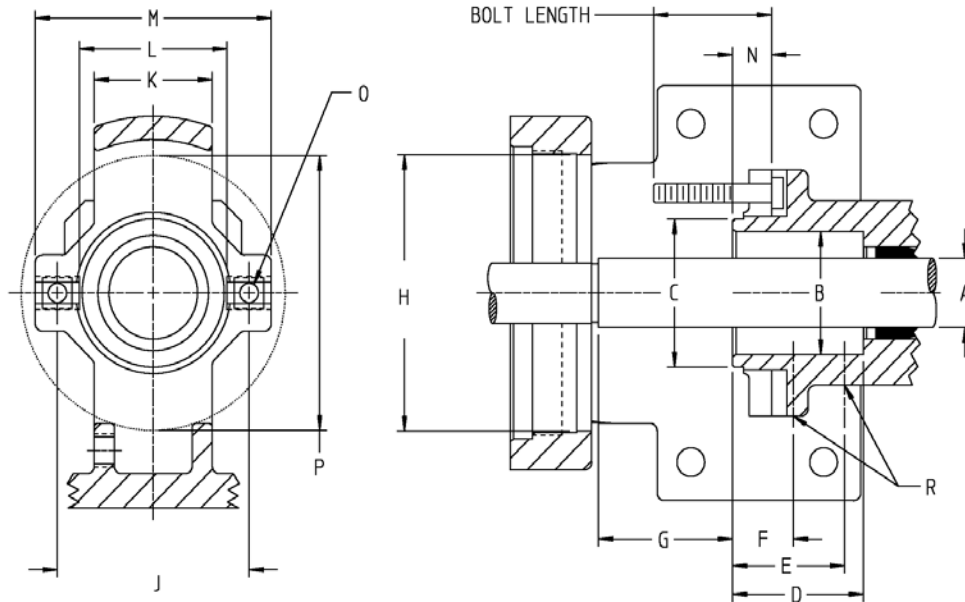

Pump Size		A	B	C	D	E	F	G	H	J	K	L	M	N	O	P	R
K & KK	In	1.44	①2.31	3.00	3.13	2.25	1.25	3.00	5.25	3.50 to 4.50	2.50	3.00	5.00	0.38	7/16	5.25	1/4
	mm		①58.7	76	80	57	32	76	133	89 to 114	64	76	127	10		133	6
L, LQ, & LL (A)	In	1.44	①2.31	3.00	3.13	2.25	1.25	4.00	5.25	3.50 to 4.50	2.50	3.00	5.00	0.44	7/16	5.25	1/4
	mm		①58.7	76	80	57	32	102	133	89 to 114	64	76	127	11		133	6
LS	In	1.62	2.38	2.80	2.70	2.25	1.16	3.52	5.25	3.25 to 4.50	3.00	2.80	5.00	0.46	7/16	5.25	1/4
	mm		60	71	69	57	30	89	133	83 to 114	76	71	127	12		133	6
Q & QS	In	2.44	3.42	4.50	4.00	2.50	1.53	4.10	6.75	5.50 to 6.25	3.20	4.50	7.20	0.56	5/8	6.75	1/4
	mm		87	114	102	64	39	104	171	140 to 159	81	114	183	14		171	6
M	In	2.44	3.44	—	3.97	2.50	1.53	4.16	6.75	5.44 to 6.26	3.28	4.50	7.20	0.72	5/8	7.37	1/4
	mm		87	—	101	64	39	106	171	138 to 159	83	114	183	18		187	6
N	In	3.44	4.69	—	5.56	1.65	—	4.91	8.81	6.75	—	—	—	—	②3/4	9.00	1/4
	mm		119	—	141	42	—	125	224	171	—	—	—	—		229	6
R & RS	In	4.50	5.75	—	5.56	1.53	—	4.79	9.81	7.75	—	—	—	—	②3/4	9.81	1/4
	mm		146	—	141	39	—	122	249	197	—	—	—	—		249	6

① Bracket is counter bored to a diameter of 2.687 inches (68 mm), 0.12 inches (3 mm) deep from stuffing box face.

② Studs are used in place of cap screws.

Section	1468
Page	1468.14
Issue	B

**LIQUID-SPECIFIC PRODUCT LINE:
CAST IRON ASPHALT PUMPS**
1224A-ASP Series™ & 1324A-ASP Series™

NPSH REQUIRED

Printed performance curves are not available.

Performance curves can be electronically generated with the Viking Pump Curve Generator on vikingpump.com.

NPSHR data is not available on the pump selector.

NPSH (Net Positive Suction Head): The NPSH_R (Net Positive Suction Head Required by the pump) is given in the table below and applies for viscosities through 750 SSU. NPSH_A (Net Positive Suction Head – Available in the system) must be greater than the NPSH_R. For a complete explanation of NPSH, see Application Data Sheet AD-19.

FOR VISCOSITIES UP TO 750 SSU – See NPSH_R table below.

NPSH_R for high viscosities can be estimated using the following method:

1. Calculate line loss for a 1 foot long pipe of a diameter matching the pump inlet port size. Use your flow rate and max viscosity.
2. Convert this value into Feet of Liquid (S.G. 1.0)
3. Add this value to the NPSH_R value in the chart below.

NPSH_R – FEET OF LIQUID (Specific Gravity 1.0), Viscosities up to 750 SSU

PUMP SIZE	PUMPS SPEED, RPM														
	100	125	155	190	230	280	350	420	520	640	780	950	1150	1450	1750
K, KK	—	1.7	1.8	1.9	2.1	2.3	2.8	3.3	4.4	6.3	9.1	—	—	—	—
L	1.6	1.8	2.0	2.2	2.5	3.0	3.8	5.0	7.3	10.8	—	—	—	—	—
LQ	1.6	1.8	2.0	2.2	2.5	3.0	3.8	5.0	7.3	10.8	—	—	—	—	—
LL	1.6	1.8	2.0	2.2	2.5	3.0	3.8	5.0	7.3	—	—	—	—	—	—
LS	1.6	1.8	2.0	2.2	2.5	3.0	3.8	5.0	7.3	10.8	—	—	—	—	—
Q, QS	1.9	2.1	2.3	2.7	3.3	4.2	6.1	8.4	12.7	—	—	—	—	—	—
M	2.1	2.3	2.8	3.4	4.3	6.0	9.0	12.7	—	—	—	—	—	—	—
N	2.1	2.3	3.5	4.5	6.3	9.5	15.0	—	—	—	—	—	—	—	—
R	6.1	7.1	8.3	10.1	12.1	15.2	—	—	—	—	—	—	—	—	—
RS	7.0	8.5	10.4	13.1	17.2	22.4	—	—	—	—	—	—	—	—	—